

## Application Note

# Operating Principle and Construction of Zirconium Dioxide Oxygen Sensors

### 1. INTRODUCTION

This application note describes the physics and concepts behind SST Sensing's range of dynamic and highly accurate oxygen sensors (illustrated). It also provides important information on the correct use and implementation which is key to getting the most from the sensor in a wide range of applications.

The sensor employs a well proven, small Zirconium Dioxide based element at it's heart and due to it's innovative design does not require a reference gas. This removes limitations in the environments in which the sensor can be operated with high temperatures, humidity and oxygen pressures all possible. SST Sensing's range of oxygen sensors are therefore ideal for use in the following applications:

- Laboratory measurements
- Combustion control of systems using natural gas, oil, biomass etc.
- Automotive emissions testing.
- Oxygen generation in medical and aerospace markets
- Aerospace fuel tank inerting applications
- Agricultural applications including composting and cultivation
- Bakery ovens and heat treatment furnaces.

Key to understanding the fundamentals of the sensor operation is the physics that govern it. So it follows that this is the best place to start.



# Application Note

## Operating Principle and Construction of Zirconium Dioxide Oxygen Sensors

### 2. BACKGROUND PHYSICS

#### 2.1 Partial pressure

##### Definition:

The partial pressure is defined as the pressure of a single gas component in a mixture of gases. It corresponds to the total pressure which the single gas component would exert if it alone occupied the whole volume.

##### Dalton's law:

The total pressure ( $p_{total}$ ) of a mixture of ideal gases is equal to the sum of the partial pressures ( $p_i$ ) of the individual gases in that mixture.

$$p_{total} = \sum_{i=1}^k p_i \quad (1)$$

From equation (1) it can be derived that the ratio of the number of particles ( $n_i$ ) of an individual gas component to the total number of particles ( $n_{total}$ ) of the gas mixture equals the ratio of the partial pressure ( $p_i$ ) of the individual gas component to the total pressure ( $p_{total}$ ) of the gas mixture.

$$\frac{n_i}{n_{total}} = \frac{p_i}{p_{total}} \quad (2)$$

$n_i$	Number of particles in gas i
$n_{total}$	Total number of particles
$p_i$	Partial pressure of gas i
$p_{total}$	Total pressure

##### Example 2.1.1:

The atmospheric pressure at sea level (under standard atmospheric conditions) is 1013.25mbar. Here the main components of **dry** air are nitrogen (78.09% Vol.), oxygen (20.95% Vol.), argon (0.927% Vol.) and carbon dioxide (0.033% Vol.). The volumetric content (%) can be equated to the number of particles ( $n$ ) since the above gases can be approximated as ideal gases.

Equation (2) can be solved for the partial pressure of an individual gas (i) to get:

$$p_i = \frac{n_i}{n_{total}} \cdot p_{total} \quad (3)$$

The oxygen partial pressure then equates to:

$$p_i = \frac{20.95\%}{100\%} \cdot 1013.25mbar = 212.28mbar$$

Of course this value is only relevant when the atmosphere is dry (0% humidity). If moisture is present a proportion of the total pressure is taken up by water vapour pressure. Therefore the partial oxygen pressure ( $PPO_2$ ) can be calculated more accurately when relative humidity and ambient temperature are measured along with the total barometric pressure.

Firstly water vapour pressure is calculated:

$$WVP = \left( \frac{H_{Rel}}{100} \right) \cdot WVP_{MAX} \quad (4)$$

WVP:	Water Vapour Pressure (mbar)
$H_{Rel}$ :	Relative Humidity (%)
$WVP_{MAX}$ :	Max Water Vapour Pressure (mbar)

For a known ambient temperature, maximum water vapour pressure ( $WVP_{MAX}$ ) can be determined from the lookup table in appendix A. The maximum water vapour pressure is also referred to as the dew point.

Partial oxygen pressure then equates to:

$$PPO_2 = (BP - WVP) \cdot \left( \frac{20.95}{100} \right) \quad (5)$$

$PPO_2$ :	Partial Pressure $O_2$ (mbar)
BP:	Barometric Pressure (mbar)
WVP:	Water Vapour Pressure (mbar)

Example 2.1.2 describes the effect of humidity reducing the partial oxygen pressure and therefore the volumetric content of oxygen.

# Application Note

## Operating Principle and Construction of Zirconium Dioxide Oxygen Sensors

### 2. BACKGROUND PHYSICS (cont)

#### Example 2.1.2:

On a typical day the following information is recorded from a calibrated weather station:

Temperature: 22°C  
 Humidity: 32%  
 Barometric Pressure: 986 mbar

Using the lookup table in appendix A,  $WVP_{MAX} = 26.43\text{mbar}$ .

$$WVP = \left(\frac{32}{100}\right) \cdot 26.43 = 8.458\text{mbar}$$

Partial oxygen pressure then equates to:

$$PPO_2 = (986 - 8.458) \cdot \left(\frac{20.95}{100}\right) = 204.795\text{mbar}$$

As we now know the oxygen partial pressure and the total barometric pressure we can work out the volumetric content of oxygen.

$$O_2 \% = \left(\frac{204.8}{986}\right) \cdot 100 = 20.77\%$$

#### 2.2 Zirconium dioxide (ZrO<sub>2</sub>):

At high temperatures > 650°C stabilised zirconium dioxide (ZrO<sub>2</sub>) exhibits two mechanisms:

1. ZrO<sub>2</sub> partly dissociates producing mobile oxygen ions and therefore becomes a solid electrolyte for oxygen. A ZrO<sub>2</sub> disc coated with porous electrodes connected to a constant DC current source allows ambient oxygen ions to be transported through the material. This liberates an amount of oxygen at the anode proportional to the charge transported (electrochemical pumping) which according to Faraday's First Law of Electrolysis is:

$$N = \frac{it}{zF} \quad (6)$$

N: Number of Moles of Oxygen Transported  
 i: Constant Current  
 t: Time (seconds)  
 z: Ionic Valence of Oxygen  
 F: Faraday Constant = 96487 C/mol

2. ZrO<sub>2</sub> behaves like an electrolyte. If two different oxygen pressures exist on either side of a piece of ZrO<sub>2</sub>, a voltage (Nernst voltage) is generated across it.

#### 2.3 Nernst Voltage:

Two different ion concentrations on either side of an electrolyte generate an electrical potential known as the Nernst Voltage. This voltage is proportional to the natural logarithm of the ratio of the two different ion concentrations.

$$\Delta V = -\frac{k_B T}{e_0} \cdot \ln\left(\frac{c_1}{c_2}\right) \quad (7)$$

k<sub>B</sub>: Boltzmann constant (k<sub>B</sub> = 1.3x10<sup>-23</sup>J/K)  
 T: Temperature in K  
 e<sub>0</sub>: Elementary charge (e<sub>0</sub> = 1.602x10<sup>-19</sup>C)  
 c<sub>i</sub>: Ion concentration in mol/kg

Either of these properties are used in many variants of oxygen sensors, but uniquely SST's oxygen sensors employ both principals simultaneously. This removes the need for a sealed reference gas making the sensor more versatile for use in a range different oxygen pressures. Section 3 further explains the construction and functionality.

# Application Note

## Operating Principle and Construction of Zirconium Dioxide Oxygen Sensors

### 3. SENSOR FUNCTION

#### 3.1 Sensor Cell Construction:

At the core of the SST Sensing oxygen sensor is the sensing cell (Fig 3.1.1). The cell consists of two zirconium dioxide ( $ZrO_2$ ) squares coated with a thin porous layer of platinum which serve as electrodes. The platinum electrodes provide the catalyst necessary for the measured oxygen to dissociate allowing the oxygen ions to be transported in and out of the  $ZrO_2$ .

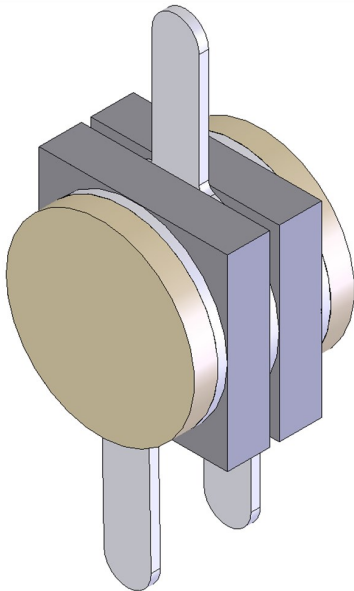

Fig 3.1.1 The Sensing Cell

The two  $ZrO_2$  squares are separated by a platinum ring which forms a hermetically sealed sensing chamber. At the outer surfaces there are two further platinum rings which along with centre platinum ring provide the electrical connections to the cell.

Two outer alumina ( $Al_2O_3$ ) discs filter and prevent any particulate matter from entering the sensor and also remove any un-burnt gases. This prevents contamination of the cell which may lead to unstable measurement readings. Fig 3.1.2 shows a cross-section of the sensing cell with all the major components highlighted.

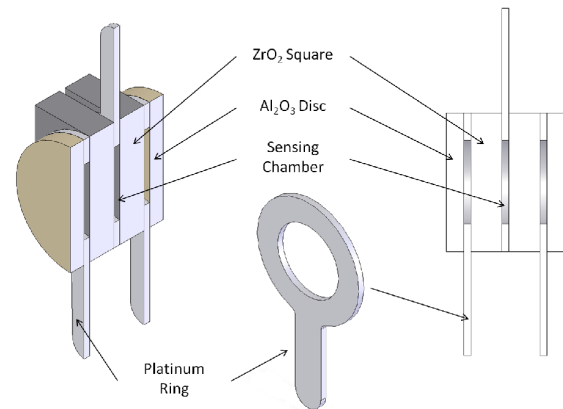

Fig 3.1.2 Cross-Section of the Sensing Cell

The cell assembly is surrounded by a heater coil which produces the necessary  $700^{\circ}C$  required for operation. The cell and heater are then housed within a porous stainless steel cap to filter larger particles and dust and also to protect the sensor from mechanical damage. Fig 3.1.3 shows the complete sensor assembly.

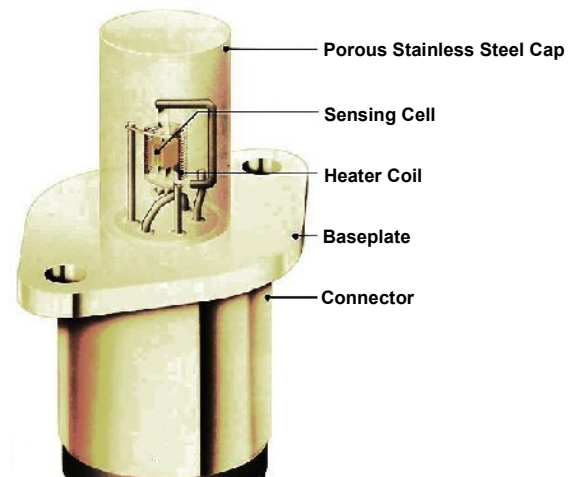

Fig 3.1.3 Complete Sensor Assembly

# Application Note

## Operating Principle and Construction of Zirconium Dioxide Oxygen Sensors

### 3. SENSOR FUNCTION (cont)

#### 3.2 Pumping Plate:

The first  $ZrO_2$  square works as an electrochemical oxygen pump, evacuating or re-pressurising the hermetically sealed chamber. Depending on the direction of the reversible DC constant current source the oxygen ions move through the plate from one electrode to the other, this in turn changes the oxygen concentration and therefore the pressure ( $P_2$ ) inside the chamber. As we only evacuate then re-pressurise the chamber, the pressure inside the chamber is always less than the ambient pressure outside the chamber. Fig 3.2.1 shows the electrical connections to the cell.

#### 3.3 Sensing Plate:

A difference in oxygen pressure across the second  $ZrO_2$  square generates a Nernst voltage which is logarithmically proportional to the ratio of the oxygen ion concentrations (See 2.3 Nernst Voltage). As the pressure inside the chamber ( $P_2$ ) is always kept less than the pressure outside of the chamber ( $P_1$ ), the voltage at sense with respect to the common is always positive.

This voltage is sensed and compared with two reference voltages and every time either of these two references are reached the direction of the constant current source is reversed. When the  $PPO_2$  is high, it takes longer to reach the pump reversal voltages than it does in a low  $PPO_2$  atmosphere. This is because a greater number of oxygen ions are required to be pumped in order to create the same ratiometric pressure difference across the sensing disc.

#### Example 3.3.1

$P_1$  is 10mbar and the set reference voltage is achieved when  $P_2$  is 5mbar. If  $P_1$  is then changed to 1bar,  $P_2$  would have to be 0.5bar in order to achieve the same reference voltage. This would involve evacuating far more oxygen ions and as the current source used to pump the ions is constant, would therefore take a lot longer.

Section 4 explains the interpretation of the generated Nernst voltage and how this corresponds to oxygen pressure.

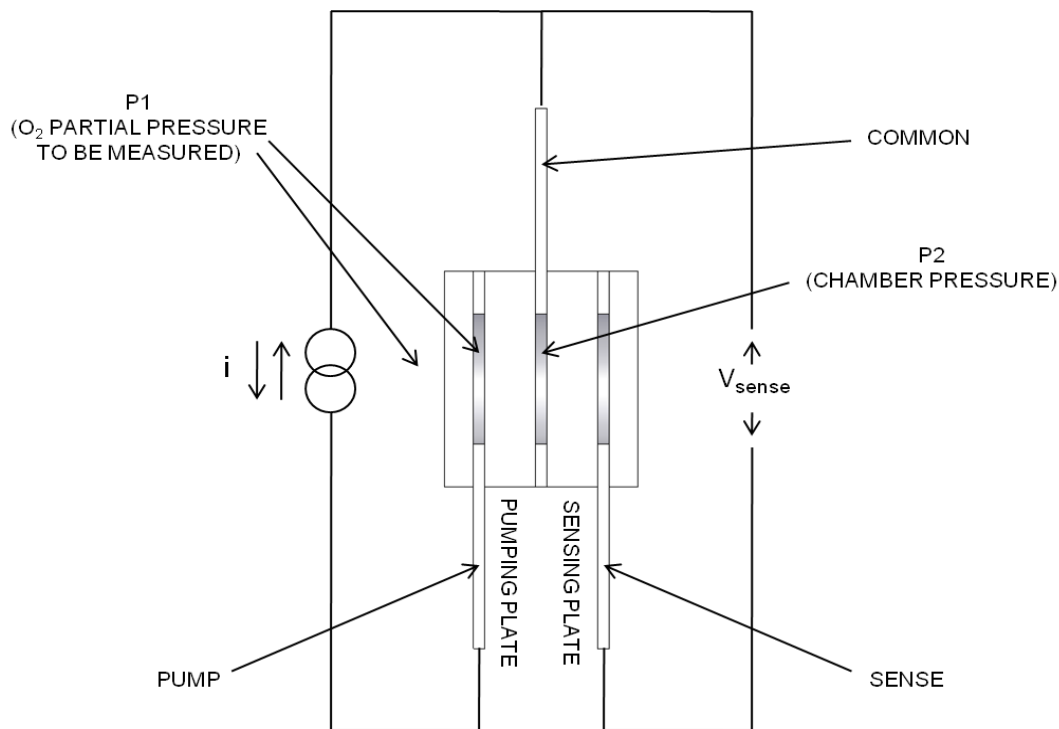

Fig 3.2.1 Electrical Connections to the Cell

# Application Note

## Operating Principle and Construction of Zirconium Dioxide Oxygen Sensors

### 4. MEASUREMENT

Most analogue sensors only have three connections, supply, ground and a linear analogue output, usually current or voltage which is proportional to the measurand. Our range of sensors instead have five connections:

#### Two Heater Connections:

The heater requires a specific voltage to ensure the correct operating temperature at the cell.

#### Three Cell Connections:

A reversible DC constant current source is applied between PUMP and COMMON in order to create the electrochemical pumping action. The resultant Nernst voltage is sensed between SENSE and COMMON.

As previously explained, when the amplitude of the sense signal hits predetermined reference levels ( $V_1$  and  $V_5$ ) the direction of the constant current source is reversed. The duration of a complete pump cycle i.e. the time taken to once evacuate and refill the chamber, depends on the partial pressure of oxygen in the gas to be measured (see Fig 4.1) This time is equivalent to the cycle duration of the Nernst voltage ( $t_p$ ). The higher the ambient oxygen pressure is, the longer it takes for the oxygen pump at constant pump current to reach the same levels. Thus, the pumping cycle and therefore the cycle time of the Nernst voltage are linearly proportional to the oxygen partial pressure.

### Practical Considerations

In theory any two values can be chosen for  $V_1$  and  $V_5$ , in practice they are chosen to:

1. Eliminate the effect of an electric double layer in the  $ZrO_2$  square formed by space charges.
2. Create the best response time for the application.
3. Eliminate temperature dependence.

### Compensating for the Electric Double Layer

Not all of the charge supplied by the constant current source contributes to a pressure change in the chamber, some is absorbed by an electric double layer formed at the platinum/ $ZrO_2$  interface as the current source is reversed. This effect is particularly noticeable at the extremes of pressure and near the pump reversal voltages. As pressure increases the amount of charge required to change the chamber pressure also increases. To reduce this effect the working chamber pressure should only vary 1-10% from the ambient pressure.

To overcome the influence of the double layer near the pump reversal points, Nernst voltages are chosen well away from  $V_1$  and  $V_5$ . ( $V_2, V_3$  and  $V_4$  in Fig 4.1 illustrate this)

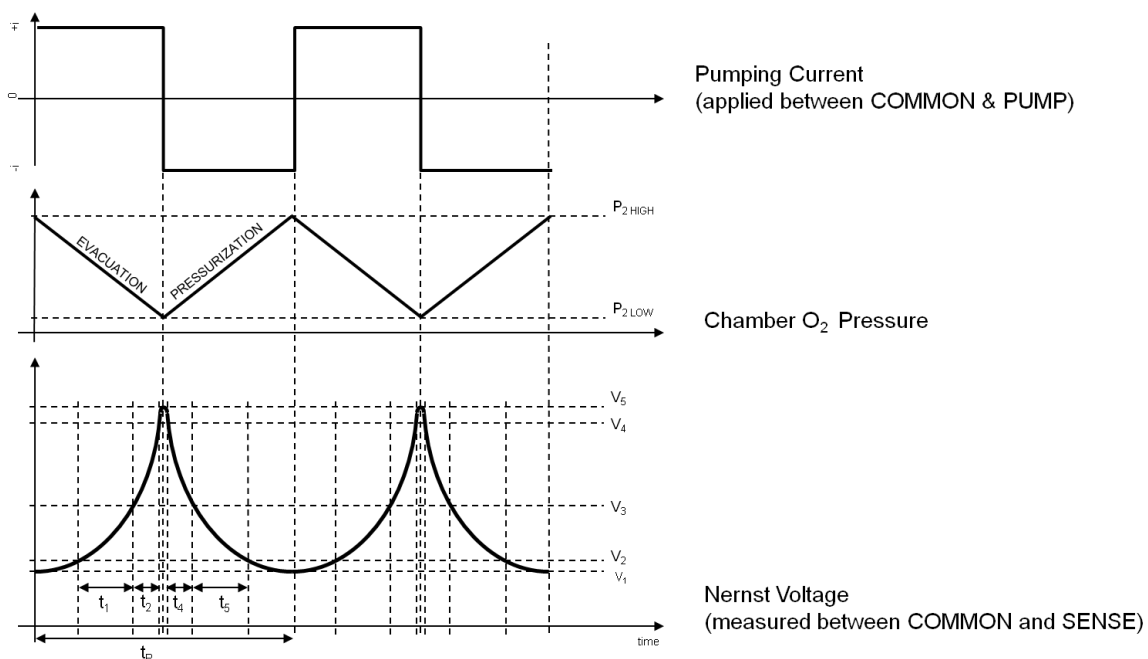

Fig 4.1 Pump Current and Generated Nernst Voltage



# Application Note

## Operating Principle and Construction of Zirconium Dioxide Oxygen Sensors

### 4. MEASUREMENT (cont)

#### Response Time

Because the pump cycle time increases as the oxygen pressure increases, at higher oxygen pressures  $V_1$  and  $V_5$  should be made close to each other in order to ensure a fast response.

#### Compensating For Temperature Dependence

It can be seen that the Nernst voltage (Equation 7) is temperature dependant. However the temperature dependence is such that under certain operating conditions, the combined temperature dependence of Nernst Law and the Gas Laws that govern oxygen can be vastly reduced. Again much of this temperature dependence occurs around the pump reversal points so by choosing to measure Nernst voltages at  $V_2, V_3$  and  $V_4$  we can make the temperature co-efficient ( $T_C$ ) virtually equal zero.

When operating in this  $T_C = 0$  mode the time taken to reach  $V_2, V_3$  and  $V_4$  are measured. These are highlighted as  $t_1, t_2, t_4$  and  $t_5$  in Fig 4.1. The revised cycle time ( $t_d$ ) is then calculated as follows:

$$t_d = (t_1 - t_2) + (t_5 - t_4) \quad (8)$$

Not only does  $t_d$  give a linear output proportional to the ambient oxygen pressure but unlike  $t_p$ , it also goes through the origin. The graph in Fig 4.2 shows the output when calculating  $t_d$  vs.  $t_p$ .

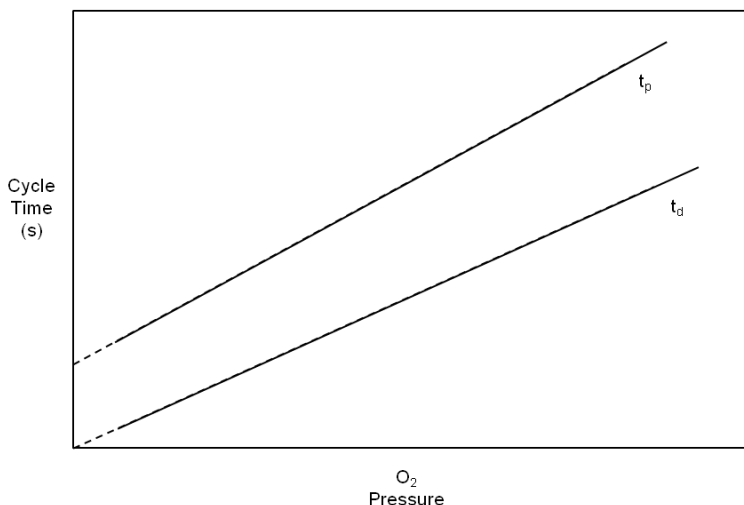

Fig 4.2  $t_d$  vs.  $t_p$

One of the major benefits of having a linear response that goes through the origin is that sensor calibration (gain) can occur at one point anywhere on the slope. By measuring  $t_p$ , two point calibration is required not only to set the gain but also to remove the zero offset.

It should also be noted that the response of both  $t_p$  and  $t_d$  are represented by a dotted line as they approach zero  $O_2$  pressure ( $PPO_2$ ). This is because the sensor by definition requires at least some ambient  $PPO_2$  in order to operate. If the  $PPO_2$  is zero the sensor, due to applied constant current source, will try to pump the  $O_2$  within the  $ZrO_2$ . This will in time damage the  $ZrO_2$  and degrade sensor performance. It is therefore imperative that the sensor is not used for prolonged periods in very low oxygen environments (less than 1 mbar  $PPO_2$ ), especially in reducing atmospheres (an atmosphere in which there is little free oxygen and oxygen is consumed).

#### Sensitivity/Slope

Sensitivity or Slope is defined as the Cycle Time ( $t_d$  or  $t_p$ ) in milliseconds divided by the  $PPO_2$  in mbar of the known calibration atmosphere.

When calculating  $t_d$  (only one calibration point), sensitivity is defined as:

$$Sensitivity = \frac{t_d}{PPO_2} \quad (9)$$

When calculating  $t_p$  (two calibration points), sensitivity is defined as:

$$Sensitivity = \frac{t_p - offset}{PPO_2} \quad (10)$$

Sensitivity/Slope for a nominal sensor, when calculating  $t_d$ , is typically 1.05ms/mbar. Though due to many factors that may influence the sensitivity (chamber volume,  $ZrO_2$  thickness etc), there is a production tolerance of  $\pm 15\%$ . This makes calibration a necessity to ensure good sensor to sensor repeatability.

# Application Note

## Operating Principle and Construction of Zirconium Dioxide Oxygen Sensors

### 4. MEASUREMENT (cont)

#### 4.2 Recommended Values for Use in Normal Atmospheric Pressures:

When using the sensor to measure  $PPO_2$  of approx 1-1000mbar (0.1-100% of typical barometric pressure), the following values are recommended:

1.  $t_d$  ( $T_c = 0$  mode)

Constant Current Source (i):	40 $\mu$ A
Pump Reversal Voltages ( $V_1$ and $V_5$ ):	40mV and 90mV
Sense Voltages ( $V_2$ - $V_3$ - $V_4$ ):	45-64-85mV

2.  $t_p$  (basic period calculation)

Constant Current Source (i):	40 $\mu$ A
Pump Reversal Voltages ( $V_1$ and $V_5$ ):	25mV and 115mV

When using the sensor in higher  $O_2$  pressures alternate values can be recommended on request.

**Due to the many benefits of operating the sensor in  $T_c = 0$  mode (calculating  $t_d$ ), this is the recommended mode of operation.**

**Calculating  $t_p$ , as it is relatively simple, is only recommended for very basic applications where high accuracy is not necessarily required.**

#### Typical Measurement Procedure:

- Oxygen sensor heats up until the correct operating temperature is reached, ~100s from cold.
- In order to begin the electrochemical pumping the cell is first evacuated by applying the constant current source between PUMP and COMMON.
- The Nernst Voltage across SENSE and COMMON increases until  $V_5$  is reached.
- The pump current connections are reversed and the constant current now flows between COMMON and PUMP. The cell begins to re-pressurise.
- The Nernst Voltage across SENSE and COMMON decreases until  $V_1$  is reached.
- When  $V_1$  is reached one pumping cycle is complete and the process is repeated.
- This cycling is repeated indefinitely and each time a complete waveform is captured,  $t_d$  or  $t_p$  is calculated. This value is then scaled by a calibration factor to give a volumetric output.

#### 4.3 Calibration to Convert to Volumetric Concentration:

SST Sensing's zirconium dioxide oxygen sensors **DO NOT** directly measure the concentration (volumetric content) of the ambient oxygen but instead measure the partial oxygen pressure. However, the volumetric content can easily be calculated from Dalton's law (see equation 2) if the total pressure of the gas mixture is known.

If a relative content (percent by volume) is to be determined, the oxygen sensor has to be calibrated in the actual measurement environment with a known oxygen concentration. Typically this would involve calibration in normal air to 20.7% (not 20.95%) to take into account average humidity levels. In order to maintain accuracy, calibration should occur regularly to remove variance caused by fluctuations in barometric/application pressure. As barometric pressure changes relatively slowly daily calibrations are recommended. Regular calibration also removes any sensor drift which is typical in the first few hundred hours of operation.

SST Sensing offer a range of interface boards with oxygen measuring ranges of 0 - 25% Vol. and 0 - 100% Vol. (in typical barometric pressure), providing either a current or voltage output. SST Sensing interface boards are designed to be auto calibrated in normal air or manually calibrated to any known percentage.

#### Typical Calibration Procedure:

- Sensor placed in calibration gas, typically normal air (20.7%  $O_2$ ), though can be any gas of known concentration.
- Oxygen sensor heats up until the correct operating temperature is reached, ~100s from cold.
- Pumping cycles commence.
- Sensor is left at the operating temperature for 5-10 mins to fully stabilise.
- Output ( $t_d$  or  $t_p$ ) is calculated. Usually over at least ten cycles to average out any noise. The greater the averaging the better.
- Output value is normalised to equal the known % of the calibration gas. When calculating  $t_d$  the calibration process is now complete.
- When calculating  $t_p$  if better accuracy is required it is recommended that a second calibration at a lower % is completed. This two point calibration will remove any zero offset. If accuracy is not critical single point calibration is sufficient.



# Application Note

## Operating Principle and Construction of Zirconium Dioxide Oxygen Sensors

### 4. MEASUREMENT (cont)

#### 4.4 Initial Sensor Drift and Active Burn-In

In the first 200hrs the sensor output can drift by up to ±3%. This is due to a number of factors including:

1. Impurities in the Zirconium Dioxide migrating to the surface of the platinum electrode bond which alters the catalytic properties.
2. Heater coil ageing.
3. The internal stainless steel surface of the cap becoming less reflective due to thermal oxidation.

Regular calibration removes the effect of initial sensor drift as the sensor output is constantly re-referenced against the known calibration gas.

However if regular calibration is not possible and the output is required to have stabilised prior to use in the application then it may be necessary to actively burn-in the sensor .

Active burn-in involves operating the sensor normally in a controlled atmosphere where the exact PPO<sub>2</sub> is known. If this is normal air then all weather data must be recorded and the PPO<sub>2</sub> calculated as previously described in Example 2.1.2.

With the PPO<sub>2</sub> known the sensor output (Td or Tp) can be normalised as described in Equation 9. By calculating slope any variance in the sensor output can be considered to be drift and not due to environmental fluctuations.

The level of stability required will be dependant on the application specifications however in general the output can be considered stable when the slope value has varied by less than ±0.2% of reading in the last 48hrs.

When performing active burn-in at SST measurements are taken at 12hr intervals and the environmental temperature is also kept constant to negate any temperature dependence the sensor output may exhibit.

#### 4.5 Using a Barometric Pressure Sensor to Scale the Sensor Output.

If regular calibrations in normal air are not possible it may be necessary to use a barometric pressure sensor in conjunction with the sensor to automatically compensate the output. This is a relatively simple process as variations in the barometric pressure change the sensor output by the same proportion. So if the barometric pressure changes by 1% the sensor output will also change by 1%.

Ideally the initial system calibration should be performed after the sensor has burned in for 200 hrs. This will ensure any sensor drift, which may effect future accuracy, has occurred beforehand.

#### Typical Calibration Procedure When Using a Barometric Pressure Sensor:

1. Sensor is placed in the calibration gas, typically normal air (20.7% O<sub>2</sub>), though can be any gas of known concentration.
2. Oxygen sensor heats up until the correct operating temperature is reached, ~100s from cold.
3. Pumping cycles commence.
4. Sensor is left at the operating temperature for 5-10 mins to fully stabilise.
5. Output (t<sub>d</sub> or t<sub>p</sub>) is calculated. Usually over at least ten cycles to average out any noise. The greater the averaging the better.
6. Output value is normalised to equal the known % of the calibration gas.
7. The Barometric Pressure at the time of the calibration is stored.

Subsequent O<sub>2</sub> and Barometric Pressure readings are then entered into following equation.

$$O_2 \text{ Compensated} = O_2 \text{ Current} * (\text{Pressure Calibration} / \text{Pressure Current}) \quad (11)$$

#### Example 4.5.1

The sensor output is calibrated to 20.7% and the barometric pressure is measured at 1000mbar. The following day the pressure has changed by 1% to 990mbar. Without compensation the O<sub>2</sub> output would also reduce by 1% to 20.493%.

Using equation 11 the compensated O<sub>2</sub> value is;

$$O_2 \text{ Compensated} = 20.493 * (1000/990)$$

$$O_2 \text{ Compensated} = 20.493 * (1.0101)$$

$$O_2 \text{ Compensated} = 20.7$$

# Application Note

## Operating Principle and Construction of Zirconium Dioxide Oxygen Sensors

### 5. DESIGNING INTERFACE ELECTRONICS

If not using one of SST Sensing's interface boards for sensor control and conditioning, this section describes the basic building blocks required to create a interface circuit.

#### 5.1 Heater Control:

The sensor requires either 4VDC or 4.35VDC (dependant on sensor cap) to create the correct operating temperature for the sensing cell. This should be measured as close to the sensor as possible because due to the high current requirement of the low resistance heater there will be voltage drops across connections and wiring. The designed adjustable voltage supply should be capable of providing at least 2A and emit minimal noise.

#### 5.2 Control Circuit Voltage Regulation:

Step down and control of input supply voltage.

#### 5.3 Start Up Delay:

Zirconium dioxide only becomes operational above 650°C and as the temperature decreases below this threshold the cell impedance increases dramatically. It is therefore important that the sensing cell is not pumped when cold. Doing so may damage the sensor as the constant current source will try and drive whatever voltage is necessary, this has been found to create an effect similar to when there is zero PPO<sub>2</sub>.

It is recommended that the sensor is warmed up for a minimum 60s before the sensor control circuitry becomes active. This delay is usually achieved in software but could also be implemented in hardware

#### 5.4 Constant Current Source:

A typical 40µA DC constant current source is required to drive the pump side of the sensing cell. It is recommended that an op amp configured as a constant current source is used. A single resistor and reference voltage are chosen to set the current with the sensor cell being the variable load placed in the feedback loop.

#### 5.5 Constant Current Source Reversal:

Connection of the constant current source between PUMP and COMMON has to be able to be reversed whenever either of the reversal voltages are met. Analogue switches are ideal for this.

#### 5.6 Output Amplification and Filtering:

As the sensed Nernst voltage is a mV signal it is practical to amplify this to a more sensible operating range before analysis. Input impedance of the chosen amplifier should be as high as possible to avoid loading the cell. Input offset should be less than 0.5mV. Noise on the buffered amplified signal should be filtered by a low pass filter with a cut-off frequency of around 250Hz. It is important not to filter the mV Nernst Voltage as this can load the cell. To improve common mode noise rejection a small value capacitor (~10nF) can be placed across the input terminals of the amplifier.

#### 5.7 Pump Reversal Voltage Reference and Comparison:

The amplified sense signal should be compared to voltage references which are the specified pump reversal voltages scaled by the same gain factor as the output amplifier. Each time either the upper or lower reference is met the constant current source should be reversed.

This part of the circuit should always start up in the condition that applies the constant current source between PUMP and COMMON as this begins the evacuation necessary to start the pumping cycle i.e. PUMP should be positive with respect to COMMON.

#### 5.8 Signal Conditioning:

A suitable microprocessor is required to monitor the amplified sense signal and continually calculate  $t_d$  or  $t_p$ . Averaging will reduce natural sensor noise with the amount of averaging set to suit the response time needs of the application. Adaptive filtering is the best solution where the amount of averaging is changed depending on the amount of variation in the calculated values.

#### 5.9 Output Conditioning:

The microprocessor output should be scaled or transformed into the required output i.e. voltage, current loop, serial etc. This may involve the use of a DAC and output drive circuitry. Filtering and required output resolution should also be taken into consideration.

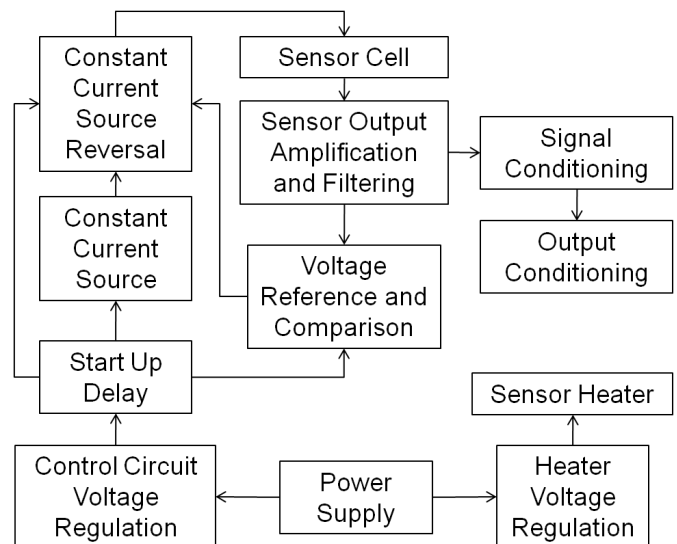

Fig 5 Oxygen Sensor Interface Block Diagram

When designing a circuit SST Sensing is happy to give whatever guidance necessary to ensure correct operation of the sensor.

# Application Note

## Operating Principle and Construction of Zirconium Dioxide Oxygen Sensors

### 6. SPECIAL NOTES AND APPLICATION HINTS

#### 6.1 Fail Safe Operation and Sensor Asymmetry:

One of the main benefits of the dynamic and active cell employed within the oxygen sensor is that it is inherently fail safe. The continual cycling and measurement of the generated Nernst voltage is effectively the heart beat of the sensor, if this stops something fatal has occurred with the cell. This can very quickly be detected by the microprocessor which can generate the relevant error code.

Looking back at Fig 4.1 we can also see that the generated Nernst voltage is symmetrical, this is also a strong indication of sensor health. If an asymmetric output waveform is detected it could be one of the following causes:

1. The heater voltage is too low
2. The sensor has been contaminated meaning the cell is not pumping correctly.
3. The hermetic seal which surrounds the sensing chamber has a leak. This means it is far more difficult to evacuate the chamber than it is to re-pressurise it.
4. The cell has been excessively loaded with capacitive impedance.

To measure asymmetry we can simply calculate the following at the same time as measuring  $t_d$  or  $t_p$ .

$$Asymmetry = \frac{(t_1 + t_2)}{(t_3 + t_4)} \quad (12)$$

The result of this calculation should ideally be 1 to indicate perfect sensor health. In production this has a tolerance of  $\pm 2.5\%$  (0.975 to 1.025).

#### 6.2 Operating the Sensor in Aggressive Humid Environments:

When operating the sensor in warm, humid environments it is important the sensor remains at a higher temperature than it's surroundings, especially if there are corrosive components in the measurement gas. During operation this is not a problem due the 700°C generated by the heater, but this means when the sensor or application is being powered down the sensor heater must be the last thing to be turned off after the temperature of the surroundings have suitably cooled. Ideally the sensor should be left powered or at a lower standby voltage (2V typically) at all times in very humid environments.

Failure to adhere to these rules will result in condensation forming on the heater and sensing cell as these will be the first components to cool due to their connections to the outside world. When the sensor is re-powered the condensation will evaporate, leaving behind corrosive salts which very quickly destroy the heater and cell as illustrated in Fig 6.2.1. Note how the sensor's external metalwork looks completely normal.



Fig 6.2.1 Internal Corrosive Damage Caused by Incorrect use in Aggressive Humid Environments

#### 6.2 Protecting from Water Droplets:

In environments where falling water droplets are likely the sensor should be protected from water falling directly onto the very hot sensor cap as this can cause massive temperature shocks to the cell and heater. Popular methods include a hood over the sensor cap or for the sensor to be mounted in a larger diameter cylinder. SST Sensing can provide such a cylinder on request.

At a very minimum the sensor cap should be angled downwards in the application as this will deflect any falling moisture and prevent the sensor cap from filling with water.

#### 6.3 Using the Sensor With Silicones:

SST Sensing's oxygen sensors, like all other Zirconium Dioxide sensors, are damaged by the presence of silicone in the measurement gas. Vapours (organic silicone compounds) of RTV rubbers and sealants are the main culprits and are widely used in many applications. These materials are often made of cheaper silicones, that when heated still outgas silicone vapours into the surrounding atmosphere. When these vapours reach the sensor the organic part of the compound will be burned at hot sensor parts, leaving behind a very fine divided Silicon Dioxide ( $SiO_2$ ). This  $SiO_2$  completely blocks the pores and active parts of the electrodes. If RTV rubbers are used we advise to use high quality, well cured materials. SST can provide guidance if there concern about use of silicone within the customer application.

A complete list of chemicals and gases that should be avoided can be found in Document AN0050 O2 Compatibility Gases and is also summarised in Appendix B.

# Application Note

## Operating Principle and Construction of Zirconium Dioxide Oxygen Sensors

### Appendix A

Lookup table for max water vapour pressure.

Temperature (°C)	Max water vapour pressure (mbar)	Temperature (°C)	Max water vapour pressure (mbar)
0	6.10	31	44.92
1	6.57	32	47.54
2	7.06	33	50.30
3	7.58	34	53.19
4	8.13	35	56.23
5	8.72	36	59.42
6	9.35	37	62.76
7	10.01	38	66.27
8	10.72	39	69.93
9	11.47	40	73.77
10	12.27	42.5	84.19
11	13.12	45	95.85
12	14.02	47.5	108.86
13	14.97	50	123.38
14	15.98	52.5	139.50
15	17.04	55	157.42
16	18.17	57.5	177.25
17	19.37	60	199.17
18	20.63	62.5	223.36
19	21.96	65	250.01
20	23.37	67.5	279.31
21	24.86	70	311.48
22	26.43	75	385.21
23	28.11	80	473.30
24	29.82	85	577.69
25	31.66	90	700.73
26	33.60	95	844.98
27	35.64	100	1013.17
28	37.78	110	1433.61
29	40.04	120	1988.84
30	42.42	130	2709.58

# Application Note

## Operating Principle and Construction of Zirconium Dioxide Oxygen Sensors

### Appendix B

#### Cross sensitivity with other gases:

Gases or chemicals that will have an influence on the life of the sensor or on the measuring results are:

#### 1. Combustible Gases

Small amounts of combustible gases will be burned at the hot Pt-electrode surfaces or  $\text{Al}_2\text{O}_3$  filters of the sensor. In general combustion will be stoichiometric as long as enough oxygen is available, the sensor will measure the residual oxygen pressure which leads to a measurement error. The sensor is not recommended for use in applications where there are large amounts of combustible gases present and an accurate  $\text{O}_2$  measurement is required.

Investigated gases were:

- $\text{H}_2$  (Hydrogen) up to 2%; stoichiometric combustion
- CO (Carbon Monoxide) up to 2%; stoichiometric combustion
- $\text{CH}_4$  (Methane) up to 2.5%; stoichiometric combustion
- $\text{NH}_3$  (Ammonia) up to 1500 ppm; stoichiometric combustion

#### 2. Heavy Metals

Vapours of metals like Zn (Zinc), Cd (Cadmium), Pb (Lead), Bi (Bismuth) will have an effect on the catalytic properties of the Pt- electrodes. Exposure to these metal vapours must be avoided.

#### 3. Halogen and Sulphur Compounds

Small amounts (< 100ppm) of Halogens and/or Sulphur compounds have no effect on the performance of the oxygen sensor. Higher amounts of these gases will in time cause readout problems or, especially in condensing atmospheres, corrosion of sensor parts. Investigated gases were:

- Halogens,  $\text{F}_2$  (Flourine),  $\text{Cl}_2$  (Chlorine)
- HCL (Hydrogen Chloride), HF (Hydrogen Fluoride)
- $\text{SO}_2$  (Sulphur Dioxide)
- $\text{H}_2\text{S}$  (Hydrogen Sulphide)
- Freons
- $\text{CS}_2$  (Carbon Disulfide)

#### 4. Reducing Atmospheres

Long time exposure to reducing atmospheres may in time impair the catalytic effect of the Pt-electrodes and has to be avoided. Reducing atmospheres are defined as an atmosphere without free oxygen or an atmosphere in which oxygen is consumed.

#### 5. Others

- Vapours (organic silicone compounds) of RTV (Room Temperature Vulcanised) rubbers are well known pollutants of Zirconia based oxygen sensors. The organic part of the compound will be burned at hot sensor parts, leaving behind a very fine divided  $\text{SiO}_2$  (Silicone Dioxide/Silica). This  $\text{SiO}_2$  completely blocks the pores and active parts of the electrodes. If RTV rubbers are used we advise to use high quality, well cured.
- Dust. Fine dust (Carbon parts/soot) might cause clogging of the porous stainless steel filter and might have an effect on the response of the sensor to oxygen changes.
- Heavy shocks or vibrations may alter sensor properties.
- Water vapour. Condensing water vapour might cause clogging of filters or internal corrosion of sensor parts. We advise to keep the sensor at operating temperature or standby temperature when exposed to exhaust gases. Direct exposure to water droplets has to be avoided.

## Application Note

# Operating Principle and Construction of Zirconium Dioxide Oxygen Sensors

### **WARNING**

All SST Sensing Ltd products are tested under nominal operating conditions during the production process. Applications for our products are varied and, as these are outside our control, specification information provided is given without legal responsibility. Customers should test under their own conditions, to ensure that the sensors are suitable for their intended application.

### **CAUTION**

Do not exceed maximum ratings.  
Carefully follow all wiring instructions, incorrect wiring can cause permanent damage to the device.  
Do not use chemical cleaning agents.

**Failure to comply with these instructions may result in product damage.**

**General Note:** SST Sensing Ltd reserves the right to make changes in product specifications without notice or liability. All information is subject to SST's own data and considered accurate at time of going to print.